



The VLT® AQUA Drive

Defining new standards for the Water/Wastewater/Irrigation market

6

year warranty

DrivePro-tection covers accidental damage from electric anomalies, corrosion, lightning or other on-site issues

100%

full load tested

VLT® drives are factory tested insuring the highest level of quality and reliability

Built-in intelligence for increased performance in all water/wastewater/irrigation applications

Dedicated

Danfoss Drives' unequalled experience was used to make the VLT® AQUA Drive the perfect match for pumps and blowers in water and wastewater systems. Water and Wastewater is a global business area for Danfoss Drives and you will find our dedicated sales and service staff all over the world, 24 hours a day.

With a wide range of powerful standard and optional features designed specifically for water and wastewater applications, the VLT AQUA Drive provides the lowest overall cost of ownership of any drive available.

Save energy

- High efficiency (>98%)
- Sleep Mode shuts off pumps when demand is low
- Automatic Energy Optimization produces typical savings of 3–5% (up to 15% possible)
- Flow compensation of setpoint
- Unique cooling concept

Save time

- Intuitive user interface with the new, award-winning local control panel (LCP)
- One drive type for the full power range
- Modular VLT design enables fast installation of options
- Automatic Motor Adaptation streamlines installation by automatically tuning the drive to the motor without spinning it or requiring the load to be decoupled
- Robust design and efficient monitoring significantly reduce maintenance requirements

Save space

- Compact, modular design
- Built-in DC-link reactors for harmonic suppression—no need for external AC input line reactors
- Optional, integrated RFI filters throughout the power range
- Integrated disconnects and fusing

Save costs

Protect your system with a series of pump-specific features:

- Cascade controller
- Dry pump detection
- End of curve detection
- Motor alternation
- 2-step ramps (initial ramp)
- Pipe fill mode
- Real-time clock
- Password protection
- Overload trip protection
- Smart logic controller
- User-selectable variable or constant torque operation
- NEMA/UL Type 12 (IP 54/55) and Nema 4X/IP66 enclosures can eliminate the need for separate enclosures

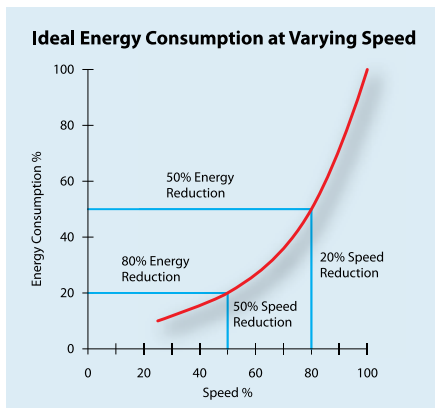

Energy savings using a VLT AQUA Drive are achieved with even a modest reduction in speed.

Reducing water losses by lowering system pressure becomes increasingly effective as the size of line breaks increase.

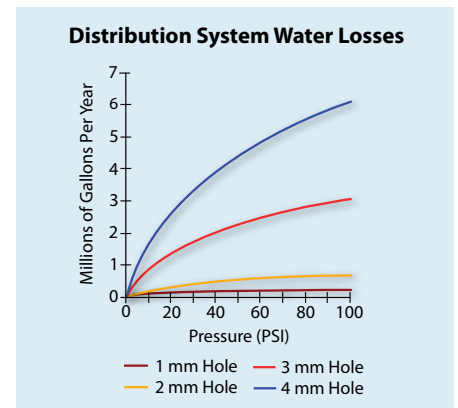

Modular design platform

Unique cooling concept

- Improves efficiency
- Reduces contaminants in electronics

Fieldbus options (A-option)

- Select any of the common fieldbus protocols

Local Control Panel (LCP)

- Six-line graphical LCP display
- I/O, relay or safety (B-option)
- I/O, Cascade Controller and relay functions

Advanced cascade controller option

- (C-option)
- 24V supply option (D-option)
- Conformally coated PCBs (optional)
- Durable in aggressive environments
- Additional higher level of conformal coating optional

AC mains disconnect and fusing (optional)

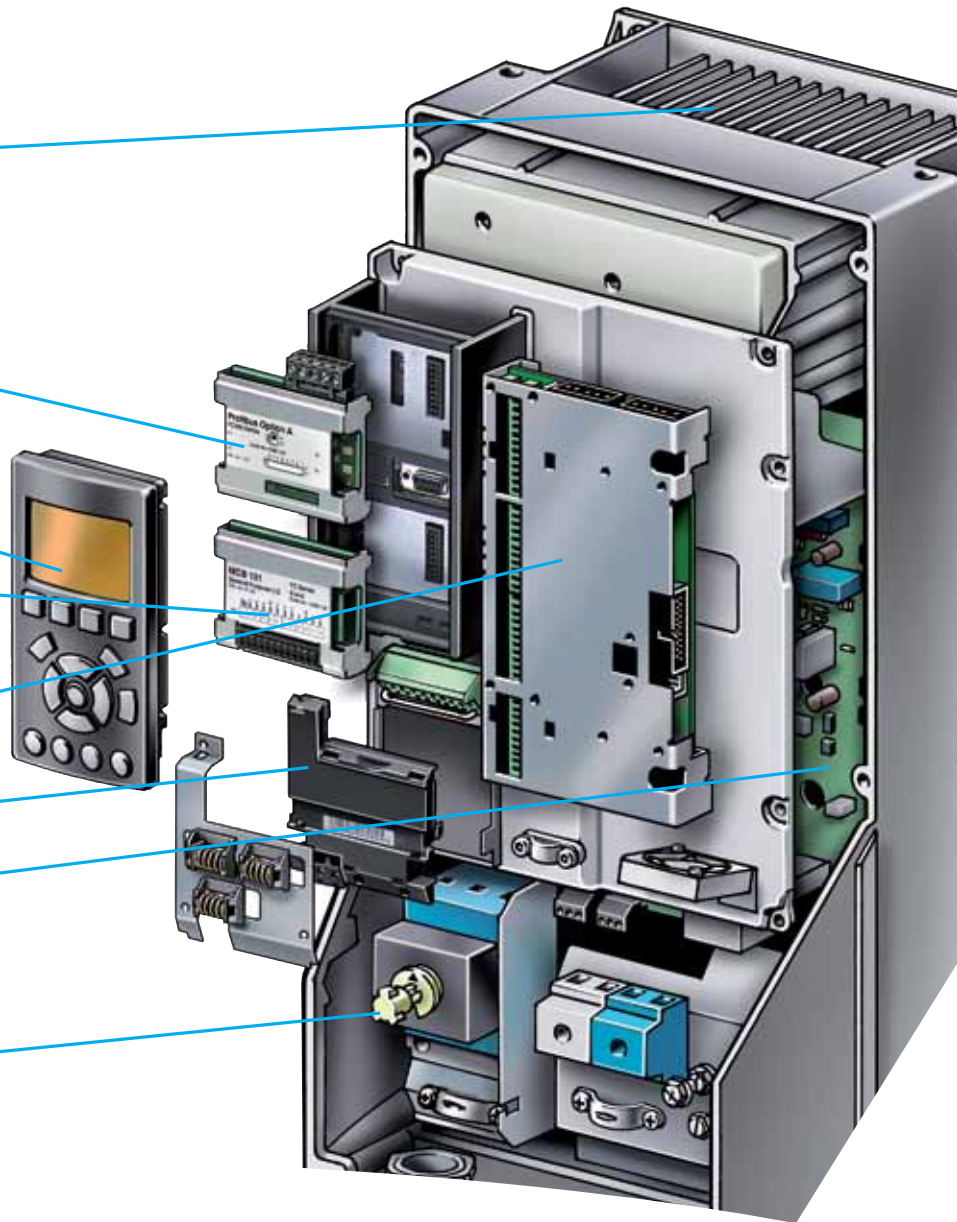

All VLT® AQUA Drives, regardless of horsepower size, have the same user interface and basic features.

Every VLT AQUA Drive is mass produced and factory tested with a load connected, as a complete assembly.

Modular plug-and-play options facilitate upgrading in the field.



Built-in DC-link reactors reduce harmonic noise and protect the drive. Integrated EMC filters are also available to minimize RFI interference (meets EN 55011 A2, A1 or B).



The VLT AQUA Drive can be remotely commissioned and monitored through a USB-pluggable cable using MCT 10 setup software.

Award-winning, user-friendly interface

Graphical display

- Informative overview
- Six lines of display
- Graphical or numerical display of information
- Readout in user-selectable engineering units
- Select from up to 27 languages as standard
- Backlit for increased visibility

Quick Menus

- Danfoss-defined Quick Menu
- My Personal Menu allows users to define their own menus of commonly accessed parameters
- Changes Made Menu displays the parameters to which changes have been made
- Function Setup Menu provides quick setup for specific applications
- Logging Menu provides access to operation history

Illumination

- Illuminated LEDs indicate which function is active

Menu structure

- Based on the field-proven matrix system used in previous VLT® Series drives
- Menu shortcuts access specific functions
- Edit and operate in different setups simultaneously

Other benefits

- The keypad is removable during operation
- Upload/download setups between drives using the keypad
- Remote mounting kit available for panel installation
- Hand / off / auto buttons for easy switching between manual and automatic control

Additional buttons

- Info: an "onboard manual" that provides specific information about each parameter
- Cancel: exits current parameter without saving changes
- Alarm log: easy access to a list of all previous alarm conditions

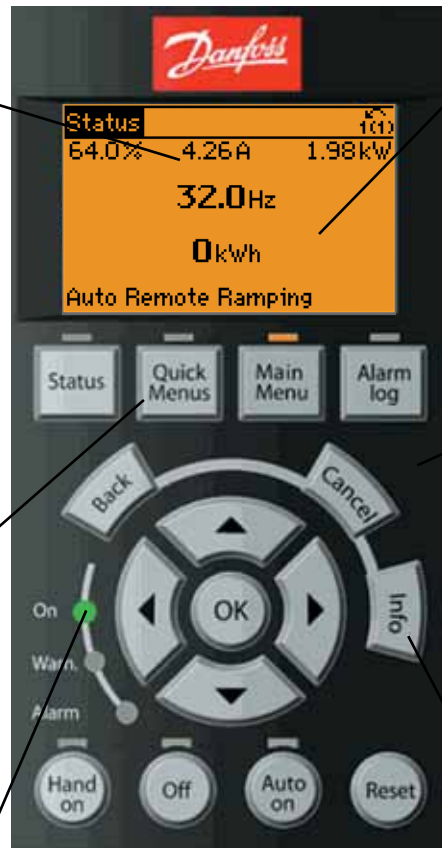

The VLT AQUA Drive has an award-winning Local Control Panel (LCP) that was designed based on user feedback. With a well-structured menu system, the VLT AQUA Drive ensures fast commissioning and easy access to its many powerful functions.



design award
winner



Powerful control and flexibility

Modular application options

MCB 101 general purpose I/O

- Inputs: 3 digital; 3 analog (voltage)
- Outputs: 2 digital; 1 analog (current)

MCB 105 relay

- Provides three additional relay outputs

MCB 107 external 24 VDC supply

- 24 VDC external supply can be connected to supply backup power to control and option cards

MCB 109 advanced analog I/O

- 3 analog inputs, 3 analog outputs
- Backup power for real-time clock

MCB 114 sensor inputs

- Three 2 or 3 wire PT100/1000
- One analog input 0/4-20mA

Integrated fused disconnect

- Available in most sizes

Cascade Controllers

Provide additional relays for staging of additional pumps:

- MCO 101 extended cascade controller controls up to five pumps
- MCO 102 advanced cascade controller controls up to eight pumps

Cascade controller option cards extend the capabilities of the VLT® AQUA Drive, allowing the control of up to eight parallel pumps configured to appear to the system as a single larger pump. Individual pumps are automatically turned on (staged) and turned off (destaged) as needed to satisfy the required system output for flow or pressure. The speed of the pumps is also controlled to provide a continuous range of system output.

Available as a factory-installed option or a field-installed accessory, cascade controller option cards provide constant pressure or level control while reducing water hammer and energy consumption. They also eliminate the need for PLCs and external controllers.

Power accessories

- **Advanced Harmonic Solutions:** Filters and low harmonics drives for applications where reducing harmonic distortion is critical
- **dV/dt filters:** For providing motor isolation protection
- **Sine filters (LC filters):** reduce motor noise
- **Common mode filters:** to reduce bearing currents and EMI/RFI

PC software tools

- **MCT 10:** provides powerful functionality for drive commissioning and servicing
- **VLT Energy Box:** Comprehensive energy analysis tool
- **MCT 31:** Harmonics calculation tool

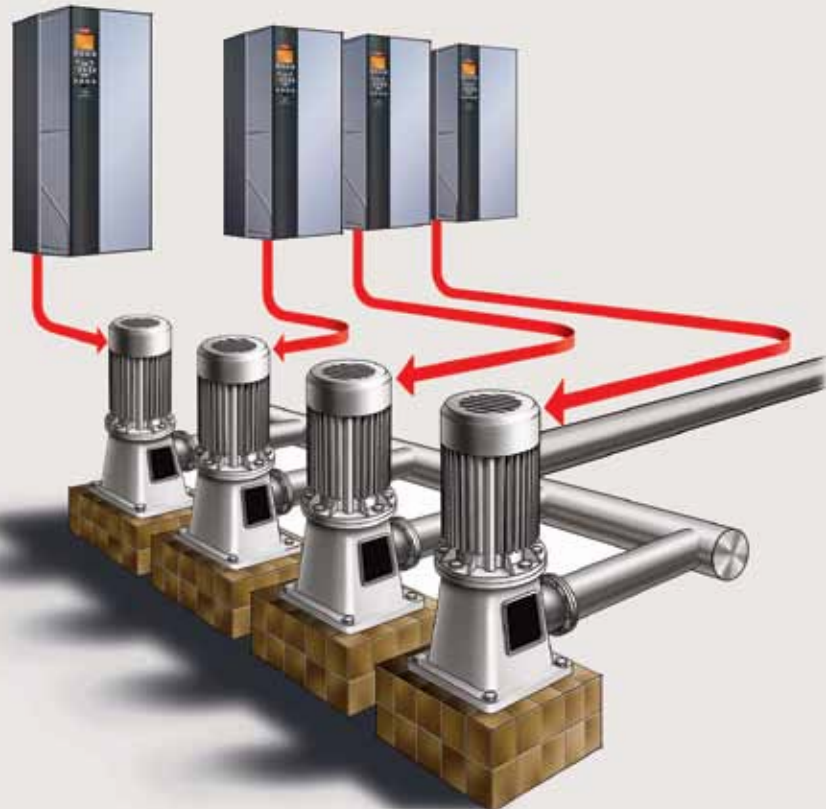

A typical VLT AQUA Drive installation utilizing the Cascade Controller option in conjunction with three additional VLT AQUA Drives to operate one to four pumps as demand requires.

Designed with the user in mind

The VLT® AQUA Drive maximizes system reliability with built-in protection:

- System overloads
- Motor failures
- Motor and drive overheating
- Voltage disturbances
- Power surges
- Loss of phase
- Phase-to-phase and phase-to-ground short circuit
- Ground fault
- Switching on input/output
- Electrical disturbances
- Overvoltage
- Overcurrent
- Undervoltage
- External fault
- Overtemperature

Minimize motor noise and heating with ASFM

With the ASFM (Adjustable Switching Frequency Modulation) function, the switching frequency is adjusted automatically in relation to the speed of the motor. As speed is reduced, the switching frequency increases to ensure optimally low motor noise and reduce motor heating.

Input line protection from extreme running conditions

Short circuit

The VLT AQUA Drive incorporates 3 hall affect sensors, one in each of the three motor phases to protect against short circuits. A short circuit between two output phases (or to ground) will shut down the drive as soon as the current exceeds the maximum value.

Line disturbances and transients

To protect itself from AC line voltage disturbances, the drive monitors all three phases and interrupts drive operation in the event of phase loss or imbalance. Transients on the AC line are suppressed by MOVs as well as zener diodes for extreme transients. Danfoss VLT AQUA Drives meet VDE 0160 (European standard—2.3 x line voltage for 1.3 msec) for transient protection.

Voltage sags and surges

The VLT AQUA Drive is designed for a wide range of operating conditions. The 480 volt drive will operate from 342–528 VAC. The 230 volt drives will operate on 180–264 VAC. 575 volt drives will operate on 495–660 VAC and 690 volt drives will operate on 472–759 VAC. Full rated motor voltage and torque can be delivered with voltage dips down to 10% under nominal AC line voltage. During an AC line drop-out, the VLT AQUA Drive continues until the intermediate circuit voltage drops below the minimum stop level, which is typically 15% below the VLT AQUA Drive's lowest rated supply voltage.

Ground fault

The VLT AQUA Drive provides complete protection from potentially damaging ground fault conditions on both the supply side and the motor side.

Nema 4X/IP66 rated enclosures

Available in IP66/NEMA 4X enclosures built to withstand harsh environments, the VLT AQUA Drive offers standard 1000-foot motor cable runs for maximum mounting flexibility. Since the drive can be installed directly at the equipment location without a protective enclosure, it's the perfect solution for lift stations, pump stations, irrigation system or any other installations that require protection against blowing dust and moisture or splashing water. All cast aluminium parts are powder coated with a durable epoxy that can stand up to most corrosive chemicals and ensure long-term reliability.



Output protection for longer motor life

VLT® AQUA Drives incorporate both DC-link reactors and motor output protection as standard design features. This provides short circuit protection and allows unlimited switching on the output without damage to the drive, eliminating the need for additional output reactors or switch interlocks.

The DC-link reactors improve overall efficiency by increasing the power factor and lowering the ripple current in the bus voltage providing an almost threefold increase in capacitor and drive life. As a result, motor operation is smooth and quiet and longer motor life can be expected.

Hall effect current transducers measure current flowing on all three motor phases. This provides highly responsive and accurate feedback to the VLT control circuit for optimum motor protection and performance.

VVC^{PLUS} output switching pattern

Unique digital VVC^{PLUS} voltage vector control provides:

- A nearly perfect output sine wave that reduces the overshooting and undershooting of voltage and current generated by standard PWM drives
- Fully rated motor voltage at rated frequency
- Increased efficiency for both drive and motor
- Full motor performance without derating; no additional heating of motor windings
- Motor cable lengths up to 1000' standard

Reduced installation cost

Dual DC-link reactors reduce the input RMS current to less than or equal to the output current. This greatly reduces the cable size requirement and the subsequent cost of installation.

Minimal harmonic distortion/ maximum power factor

DC-link reactors reduce the harmonic distortion currents that a variable frequency drive injects back into the AC line. The properly sized reactors in a VLT AQUA Drive can reduce line harmonic currents by up to 40% of the fundamental current. This eliminates the need and cost of additional AC line reactors and their resultant line voltage reduction.

Thermal protection for the drive and motor

The ETR (Electronic Thermal Relay) is an open loop method built into the VLT AQUA Drive software to guard against motor overheating, requiring no additional sensors or wiring. This function is UL recognized (Class 20) as an effective guard against motor thermal overload.

The VLT AQUA Drive has built-in thermal protection and also accepts thermistor signal input from the motor to create closed loop thermal protection for the entire system.

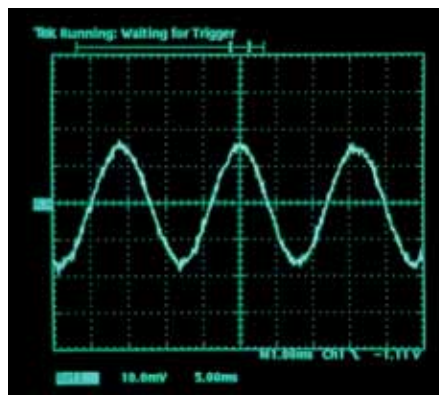
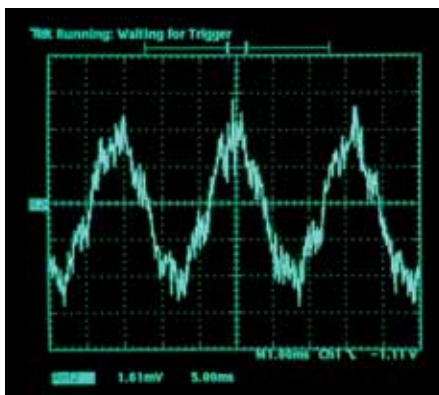

Brand "X" PWM scope trace (left) compared to smoother VVC^{PLUS} scope trace (right).

Cost effective harmonic reduction

Danfoss has spent over 50 years developing cutting edge, innovative VFD technology and we have the solutions that will fit your needs...just ask us or download MCT31 from our website for quick engineered harmonic solutions.

DC line reactors

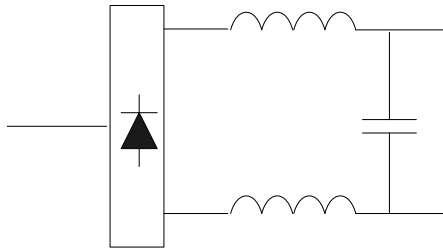

Advanced Harmonic Filter

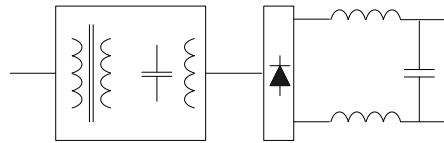

- Reduces all harmonics, not just low order
- Lowest cost of ownership
- 5 – 15% THiD

- DC-Inductors are built-in as standard
- Offers moderate harmonic reduction
- Good RMS current reduction
- 30-45% THiD

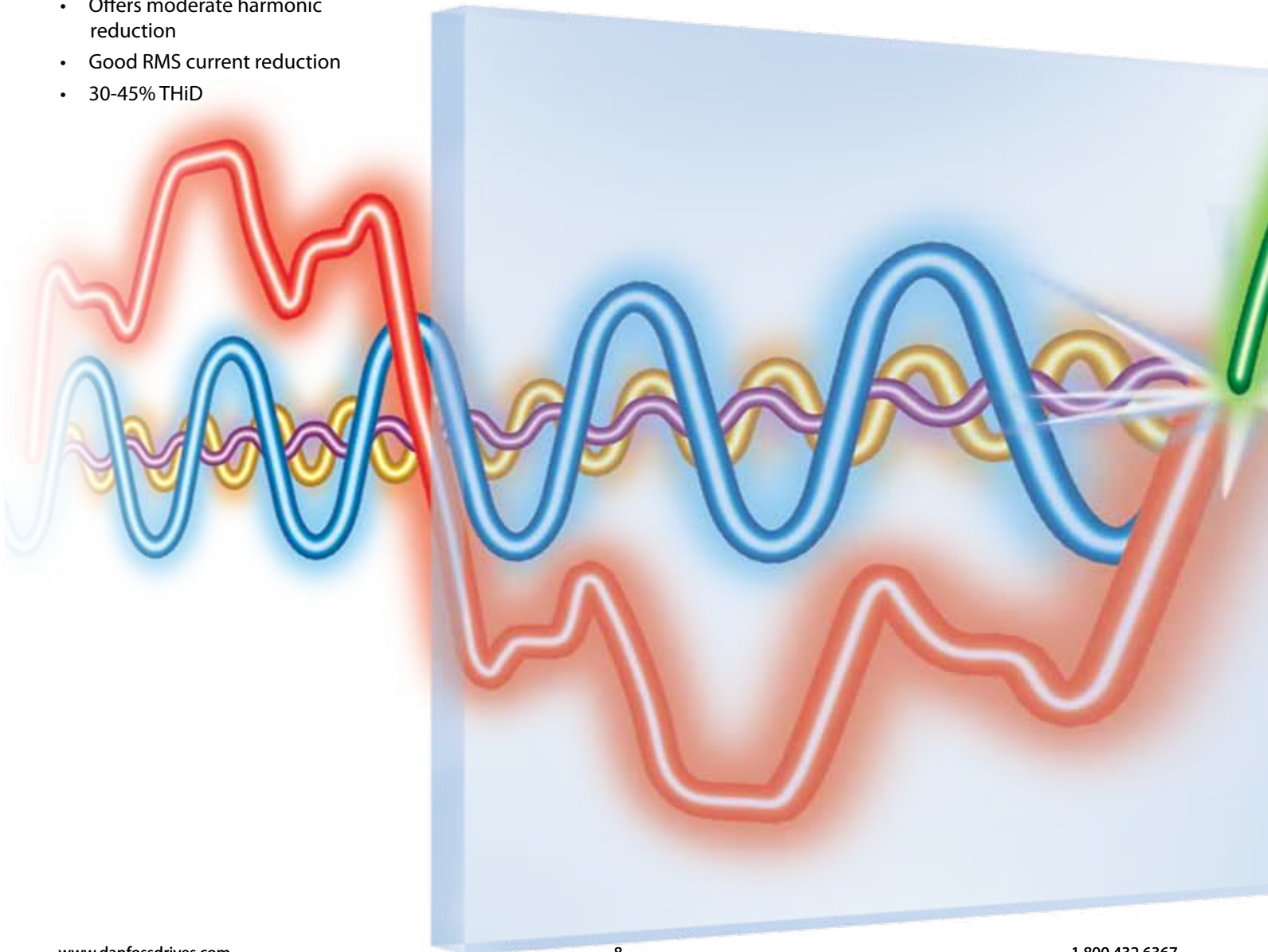

... what is the best solution?

Active Front End

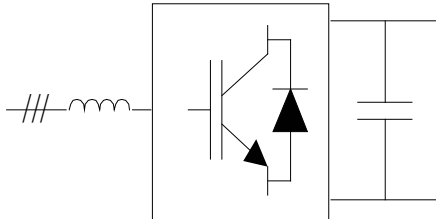

- Utilizes IGBT's in the rectifier section
- Offers best harmonic reduction
- Good for regeneration of power
- Small footprint, very compact
- <5% THiD

Multi-Pulse Drives

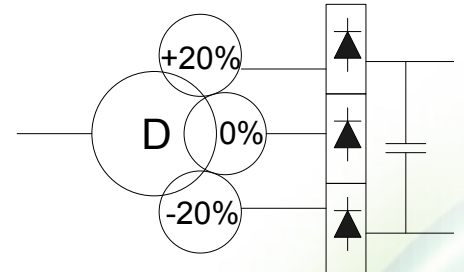

Active Filters & Low Harmonic Drives

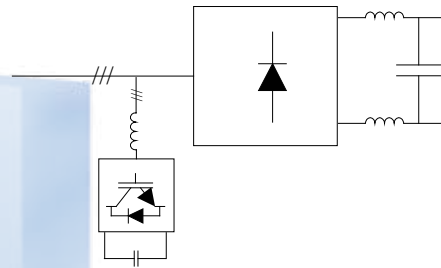

- Offers superior harmonic reduction
- Cancels distortion by monitoring and inducing an equal and opposite signal
- Extensive tolerance to load and grid imbalances
- Reduces harmonics from multiple sources
- Power factor and load balance correction
- <5% THiD

- Proven technology
- Drive power is phase shifted by a transformer to reduce harmonics
- Offers fair performance
- Dependant on high load and grid stability
- 12 pulse Front End reduces <7th harmonics
- 18 pulse Front End reduces <13th harmonics
- 5 - 14% THiD

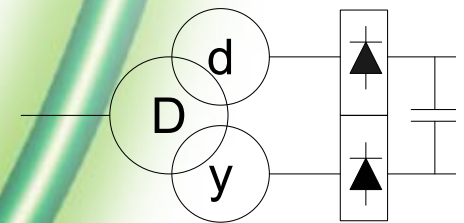

Dedicated features

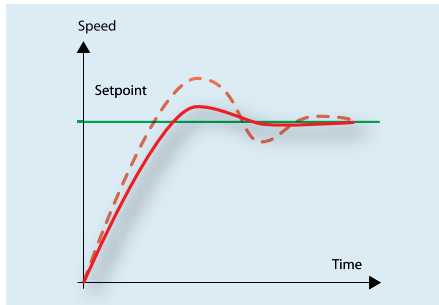

Automatic tuning of PI controllers

The VLT® AQUA Drive offers up to four separate PID loops for controlling multiple processes, each of which is automatically tuned to provide optimal performance.

The drive monitors how the system reacts to corrections and learns from this data to quickly achieve precise and stable operation. Gain factors for PI are continuously adjusted to compensate for changing characteristics of the loads. Knowing the exact P and I settings at startup is not necessary, making commissioning easier.

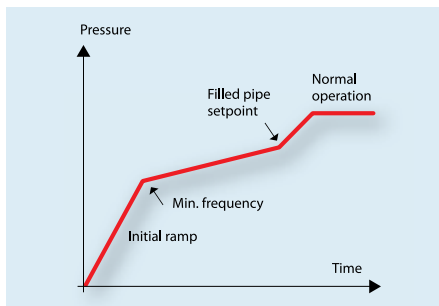

Pipe Fill Mode

The VLT AQUA Drive can provide controlled (closed loop) filling of pipes, preventing water hammer, burst water pipes and damage to sprinkler heads. This feature is particularly valuable in applications that are vulnerable to these types of damage, such as irrigation systems and water supply systems.

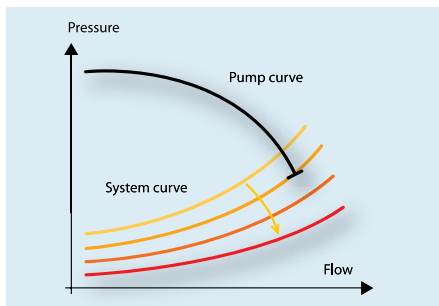

End of Pump Curve Detection

The VLT AQUA Drive can detect breaks and leakage in supply lines by comparing pump speed with the system pressure. The drive can be set to trigger an alarm, shut off the pump, or perform some other programmed action whenever a pump is found running at full speed without creating the desired pressure—a situation that usually indicates a break in the system.

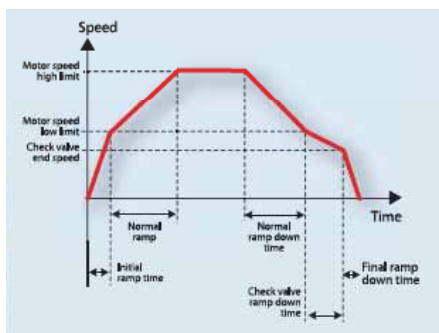

Check Valve Ramp

The Check Valve Ramp prevents water hammering as the pump stops and the check valve closes.

The Check Valve Ramp slowly ramps down the pump speed around the value where the check valve ball is about to shut.

... for water and wastewater applications

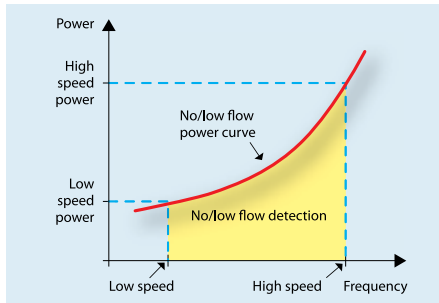

Dry Pump Protection

The VLT® AQUA Drive constantly evaluates the condition of the pump, based on internal frequency/ power measurements. When power consumption drops too low— indicating a no or low flow situation— the VLT AQUA Drive will shut down the pump.

Sleep Mode

Sleep Mode keeps pump wear and power consumption to an absolute minimum. In low flow situations, the VLT AQUA Drive will boost the system pressure and then shut down the pump. It will continue to monitor the system pressure and restart when the pressure falls below the required level.

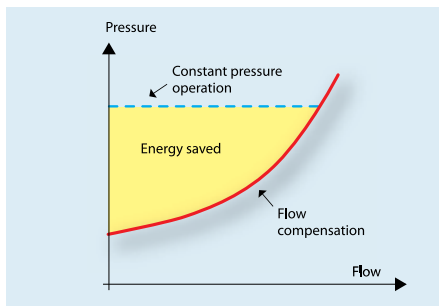

Flow compensation

The flow compensation feature of the VLT AQUA Drive takes advantage of the fact that flow resistance decreases with reduced flow. Using this information, the pressure setpoint is reduced as necessary, thereby saving energy.

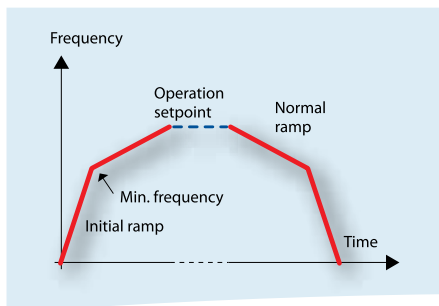

Initial/Final Ramp

Initial ramp provides rapid acceleration of pumps to a desired minimum speed, at which time the normal ramp takes over. This prevents damage to thrust bearings and overheating of the pump.

The final ramp decelerates pumps to avoid unintended closure of check valves and water hammer.

Single-phase line supply

Single-phase VLT AQUA Drives can be wired to plug into a standard single-phase outlet. These drives can then be connected to three-phase pumps, fans, blowers, and more. It's just like getting three-phase power from a standard 220–240V power socket.

Payback time indication

One of the main reasons for using a VLT Series drive is the minimal payback time due to energy savings. The VLT AQUA Drive comes with a unique feature that continuously displays the time remaining before the drive pays for itself.

Motor Alternation

This built-in logic controls alternation between two pumps in duty/stand-by applications. Running the stand-by pump prevents sticking and lubricates the seals.

An internal timer assures equal usage of the pumps.

VLT® AQUA Drive specifications

Mains supply (L1, L2, L3):

Supply voltage	200–240 V ±10%
Supply voltage	380–480 V ±10%
Supply voltage	525–690 V ±10%
Supply frequency	50/60 Hz
Max. imbalance temporary between line phases	3.0% of rated supply voltage
Displacement Power Factor (cosφ)	near unity (> 0.98)
True power factor (λ)	≥ 0.9
Switching on input supply L1, L2, L3	1–2 times/min.

Output data (U, V, W):

Output voltage	0–100% of supply voltage
Output frequency	0–120 Hz
Rated motor frequency	50/60 Hz
Switching on output	Unlimited
Ramp times	1–3600 sec.
Closed loop	0–132 Hz
Maximum motor cable length	1000 ft.

VLT AQUA Drive can provide 110% current for 1 minute. Higher overload rating is achieved by oversizing the drive.

Torque Characteristics:

Starting torque	maximum 110% for 1 min.*
Starting torque maximum	120% up to 0.5 sec.*
Overload torque	maximum 110% for 1 min.*

*Percentage relates to the nominal torque for the VLT AQUA Drive.

Control Characteristics:

Resolution of output frequency at 0–120 Hz	: +/- 0.003 Hz
System response time (terminals 18, 19, 27, 29, 32, 33)	: ≤ 2 ms
Speed control range (open-loop)	1:100 of synchronous speed
Speed accuracy (open-loop)	30 - 4000 rpm: Maximum error of ±8 rpm

All control characteristics are based on a 4-pole asynchronous motor.

Digital inputs:

Programmable digital inputs (standard)	6**
Additional digital inputs available with MCB 101 general purpose I/O card (option)	3
Logic	PNP or NPN
Voltage level	0–24 V DC

** 2 can be used as digital outputs

Analog inputs:

Analog inputs (standard)	2
Additional analog inputs available with MCB 101 general purpose I/O card (option)	2
Additional analog inputs available with MCB 109 advanced analog I/O card (option)	3
Modes	Voltage or current
Voltage level	0 to +10 V (scaleable)
Current level	0/4 to 20 mA (scaleable)

Pulse inputs:

Programmable pulse inputs (standard)	2 [†]
Additional pulse inputs available with MCB 101 general purpose I/O card (option)	3 [†]
Voltage level	0–24 V DC (PNP positive logic)
Pulse input accuracy	(0.1–110 kHz)

[†] Some of the digital inputs can be used as pulse inputs

Analog output:

Programmable 0/4–20 mA analog outputs (standard)	1
Additional 0/4–20 mA analog outputs available with MCB 101 general purpose I/O card (option)	1
Additional 0–10 VDC analog outputs available with MCB 109 advanced analog I/O and battery backup card (option)	3
Current range at analog output	3 0/4–20mA

Digital outputs:

Programmable digital/pulse outputs (standard)	2
Additional digital outputs available with MCB 101 general purpose I/O card (option)	2
Voltage level at digital/frequency output	0 - 24 V
Max. output current (sink or source)	40 mA
Max. load at frequency output	1 kΩ
Max. capacitive load at frequency output	10 nF
Minimum output frequency at frequency output	0 Hz
Maximum output frequency at frequency output	32 kHz
Accuracy of frequency output	Max. error: 0.1% of full scale
Resolution of output frequency	12 bit

Relay outputs:

Programmable relay outputs (standard)	2 ^{††}
Additional relay outputs available with MCB 105 relay card (option)	3 ^{††}

^{††} (240 VAC, 2 A and 400 VAC, 2 A)

Control card performance:

Scan interval	5 ms
24V DC output max. load	200 mA
10V DC output voltage	10.5 V ±0.5 V
10V DC output max. load	15 mA

Control card, USB serial communications:

USB standard	1.1 (Full speed)
USB plug	USB type B "device" plug

Fieldbus communication:

Standard, built in	FC Protocol, Modbus RTU
Optional modules (field-installable)	Profibus, DeviceNet, Ethernet/IP, Modbus TCP

Ambient temp:

up to 55° C

Current and power ratings

Single-phase						Three-phase													
1 x 200–240 VAC			1 x 380–480 VAC			3 x 200–240 VAC			3 x 380–480 VAC			3 x 525–600 VAC			3 x 525–690 VAC				
Output current [A]	Typical shaft output		Output current [A]	Typical shaft output		Output current [A]	Typical shaft output		Output current [A]	Typical shaft output		Output current [A]	Typical shaft output		Output current [A]	Typical shaft output			
	200-240 V	kW		HP	200-240 V		kW	HP		380–440 V	441–480 V		kW	HP		575 V	kW		HP
						1.8	0.25	0.33										PK25	
						2.4	0.37	0.5	1.3	1.2	0.37	0.5						PK37	
						3.5	0.55	0.75	1.8	1.6	0.55	0.75						PK55	
						4.6	0.75	1	2.4	2.1	0.75	1	1.7	0.75	1.0			PK75	
6.6	1.1	1.5				6.6	1.1	1.5	3	2.7	1.1	1.5	2.4	1.1	1.5			P1K1	
7.5	1.5	2				7.5	1.5	2	4.1	3.4	1.5	2	2.7	1.5	2			P1K5	
10.6	2.2	3				10.6	2.2	3	5.6	4.8	2.2	3	3.9	2.2	3			P2K2	
12.5	3	4				12.5	3	4	7.2	6.3	3	4	4.9	3	4			P3K0	
16.7	3.7	5				16.7	3.7	5										P3K7	
									10	8.2	4	5	6.1	4	5			P4K0	
24.2	5.5	7.5				24.2	5.5	7.5	13	11	5.5	7.5	9	5.5	7.5			P5K5	
30.8	7.5	10	14.5	7.5	10	30.8	7.5	10	16	14.5	7.5	10	11	7.5	10			P7K5	
			21	11	15	46.2	11	15	24	21	11	15	18	11	15			P11K	
59.4	15	20				59.4	15	20	32	27	15	20	22	15	20			P15K	
			34	18.5	25	74.8	18.5	25	37.5	34	18.5	25	27	18.5	25			P18K	
88	22	30	65	37	50	88	22	30	44	40	22	30	34	22	30			P22K	
						115	30	40	61	52	30	40	41	30	40			P30K	
						143	37	50	73*	65*	37*	50*	52	37	50			P37K	
						170	45	60	90	80	45	60	62	45	60	54	45	50	P45K
									106	105	55	75	83	55	75	73	55	60	P55K
									147	130	75	100	100	75	100	86	75	75	P75K
									177	160	90	125	131	90	125	108	90	100	P90K
									212	190	110	150				131	110	125	P110
									260	240	132	200				155	132	150	P132
									315	302	160	250				192	160	200	P160
									395	361	200	300				242	200	250	P200
									480	443	250	350				290	250	300	P250
									600	540	315	450				344	315	350	P315
									658	590	355	500							P355
									745	678	400	600				400	400	400	P400
									800	730	450	650				450	450	450	P450
																500	500	500	P500
																570	570	600	P560
																630	630	650	P630

Dimensions [in]

		Chassis/IP20†		NEMA 1/IP21						
		A2	A3	B1	B2	C1	C2	D1	D2	E1
Height		10.6	10.6	18.9	25.6	26.8	30.3	47.6	62.6	78.7
Width	without C option	3.5	5.1	9.5	9.5	12.1	14.6	16.5	16.5	23.6
	with one C option	5.1	6.7							
Depth	with two C options	5.9	7.5							
	without A or B option	8.1	8.1	10.2	10.2	12.2	13.2	15.0	15.0	19.4
	with A or B option	8.6	8.6							

		NEMA 12/IP55		NEMA 4X/IP66		NEMA 12/IP54				
		A4	A5	B1	B2	C1	C2	D1	D2	E1
Height		14.17	16.5	18.9	25.6	26.8	30.3	47.6	62.6	78.7
Width		7.87	9.5	9.5	9.5	12.1	14.6	16.5	16.5	23.6
Depth		7.5	7.9	10.2	10.2	12.2	13.2	15.0	15.0	19.4

		Protected Chassis/IP20						
		B3	B4*	C3*	C4	D3	D4	E2
Height		15.7	20.4	20.7	26.0	41.2	52.2	60.9
Width	without C option	6.5	9.1	12.1	14.6	16.1	16.1	23.0
	with one C option	8.9						
Depth	without A or B option	9.8	9.5	13.1	13.1	14.8	14.8	19.6
	with A or B option	10.3						

* 240V P18K drives and 460V P37K drives in IP20 enclosures are B4, not C3.

† An optional NEMA 1 kit is available for A2 and A3 frames, which adds 4 inches to height.



EnVisioneering

DrivePro™ Profession Drives Support minimizes downtime expense and enables your personnel to focus on core business activities

Onsite Service Warranty extends the standard parts and repair labor warranty up to 6 years from date of factory shipment and enhances support by including travel expense coverage from day one. Onsite coverage is available throughout the continental United States and Canada, Oahu Hawaii and Anchorage Alaska. Repairs and replacements are completed by factory certified technicians utilizing original equipment parts.

DrivePro-tection provides an even greater level of customer security by covering accidental damage to the drive in addition to coverage of normal product wear and defects in material or workmanship. Coverage includes lightning strikes, exposure to moisture or corrosives and collision damage after delivery. Like all other DrivePro coverage programs, Danfoss reserves the right to deny coverage due to shipping damage, product misapplication, vandalism, chronic environmental issues or facility disaster.

DrivePro Services provide the most complete drives support coverage available. Factory direct technical support is available via phone 24/7. Start-up and preventative maintenance services by factory certified technicians are available. Drive repair service at the North America VLT® Drives factory is also available. Contact your sales representative or the Danfoss DrivePro sales team for more information.

www.danfossdrives.com

Danfoss can accept no responsibility for possible errors in catalogs, brochures and other printed material. Danfoss reserves the right to alter its products without notice. This also applies to products already on order provided that such alterations can be made without subsequential changes being necessary in specifications already agreed. All trademarks in this material are property of the respective companies. Danfoss and the Danfoss logotype are trademarks of Danfoss A/S. All rights reserved.

Danfoss VLT Drives
4401 N. Bell School Rd.
Loves Park, IL, 61111, USA
Phone: 1.800.432.6367
1.815.639.8600
Fax: 1.815.639.8002

Danfoss VLT Drives
8800 W. Bradley Rd.
Milwaukee, WI 53224, USA
Phone: 1.800.621.8806
1.414.335.8800
Fax: 1.414.355.6117